

VIEW WINDOW INSTALLATION INSTRUCTIONS

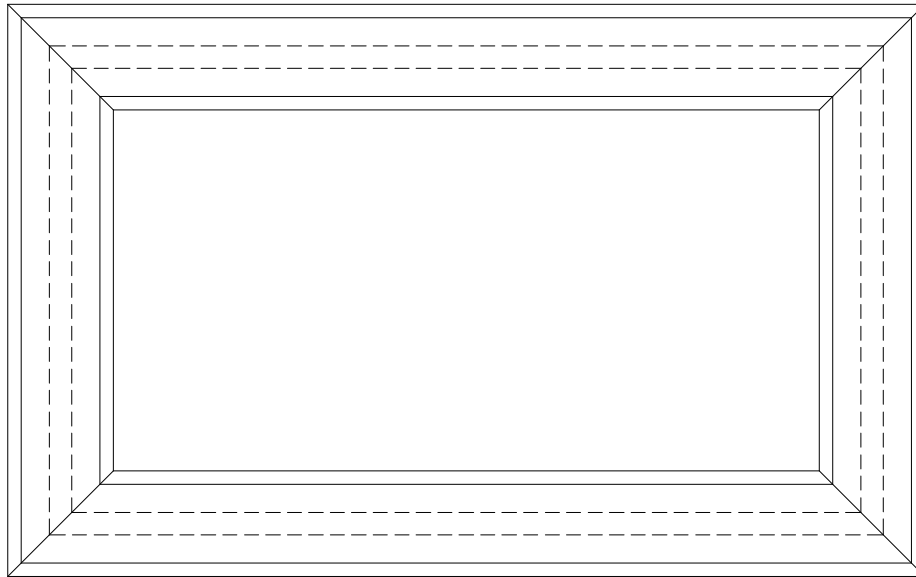

VIEW WINDOW:

1. CHECK ROUGH OPENING FOR PLUMB AND SQUARE BEFORE INSTALLATION.
2. INSTALL OUTER FRAME AND SECURE WITH SCREW FROM INSIDE FRAME FLANGE. IF FRAME IS HEATED, INSERT FRAME WIRES INTO JUCTION BOX.
3. CAULK AROUND FRAME PERIMETER TO ASSURE AN AIRTIGHT SEAL.
4. INSTALL SEALED GLASS UNIT FROM INSIDE INTO FRAME. IF GLASS UNIT IS HEATED, INSERT GLASS WIRES INTO JUCTION BOX.
5. CAULK AROUND SEALED GLASS UNIT PERIMETER TO ASSURE AN AIRTIGHT SEAL.
6. INSTALL INNER FRAME AND SECURE WITH SCREW ON FRAME FLANGE.

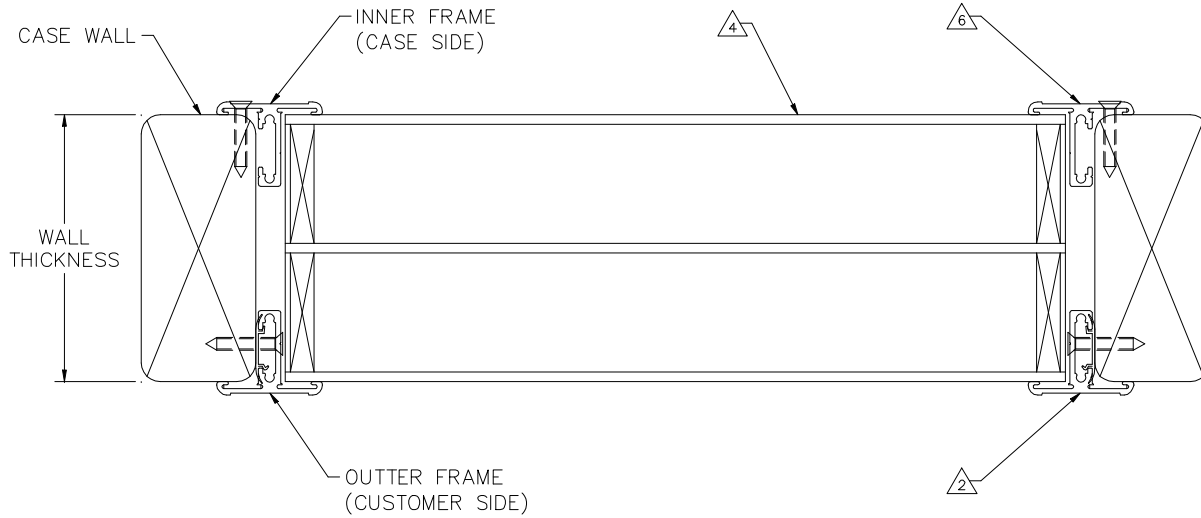
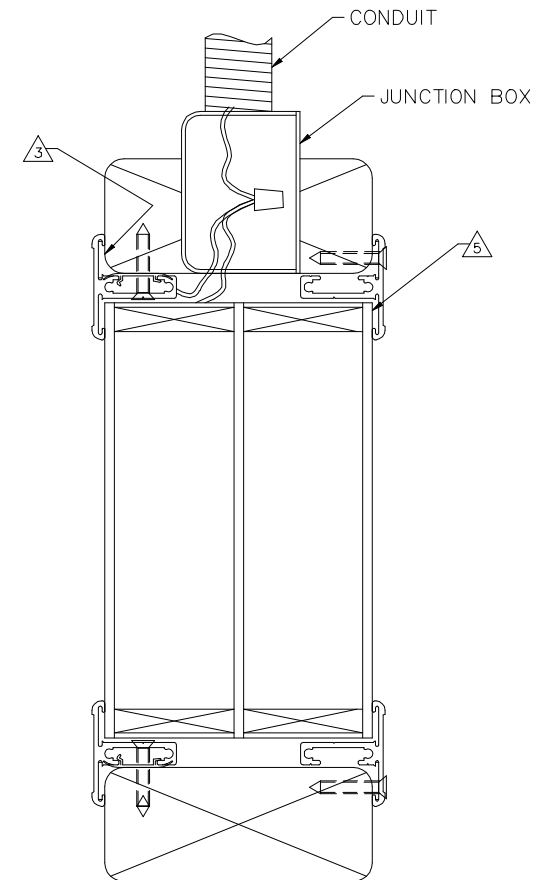

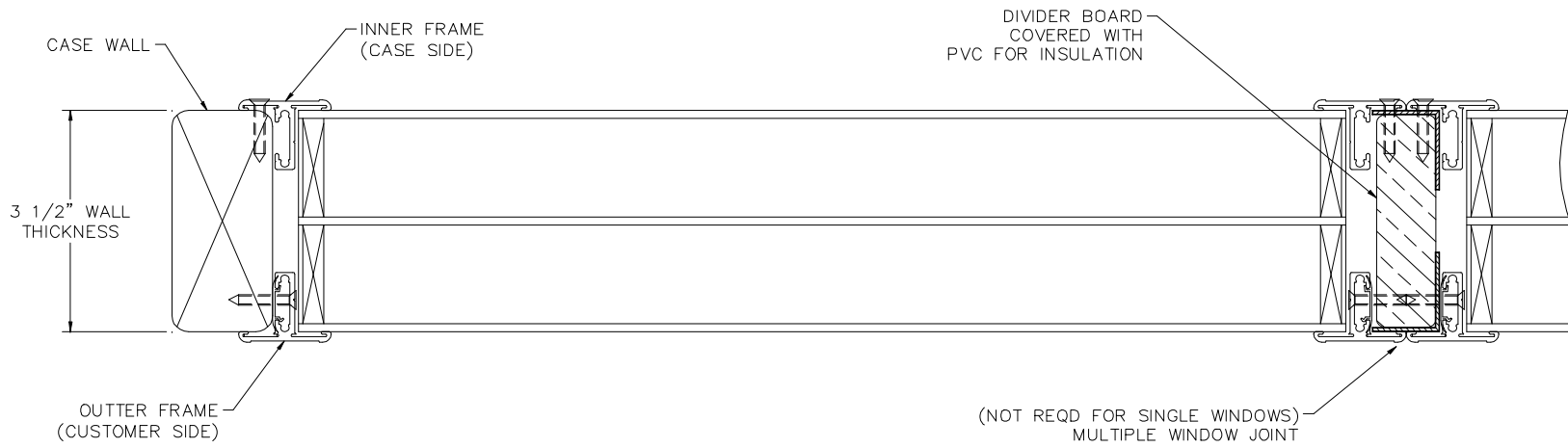

VIEW WINDOW

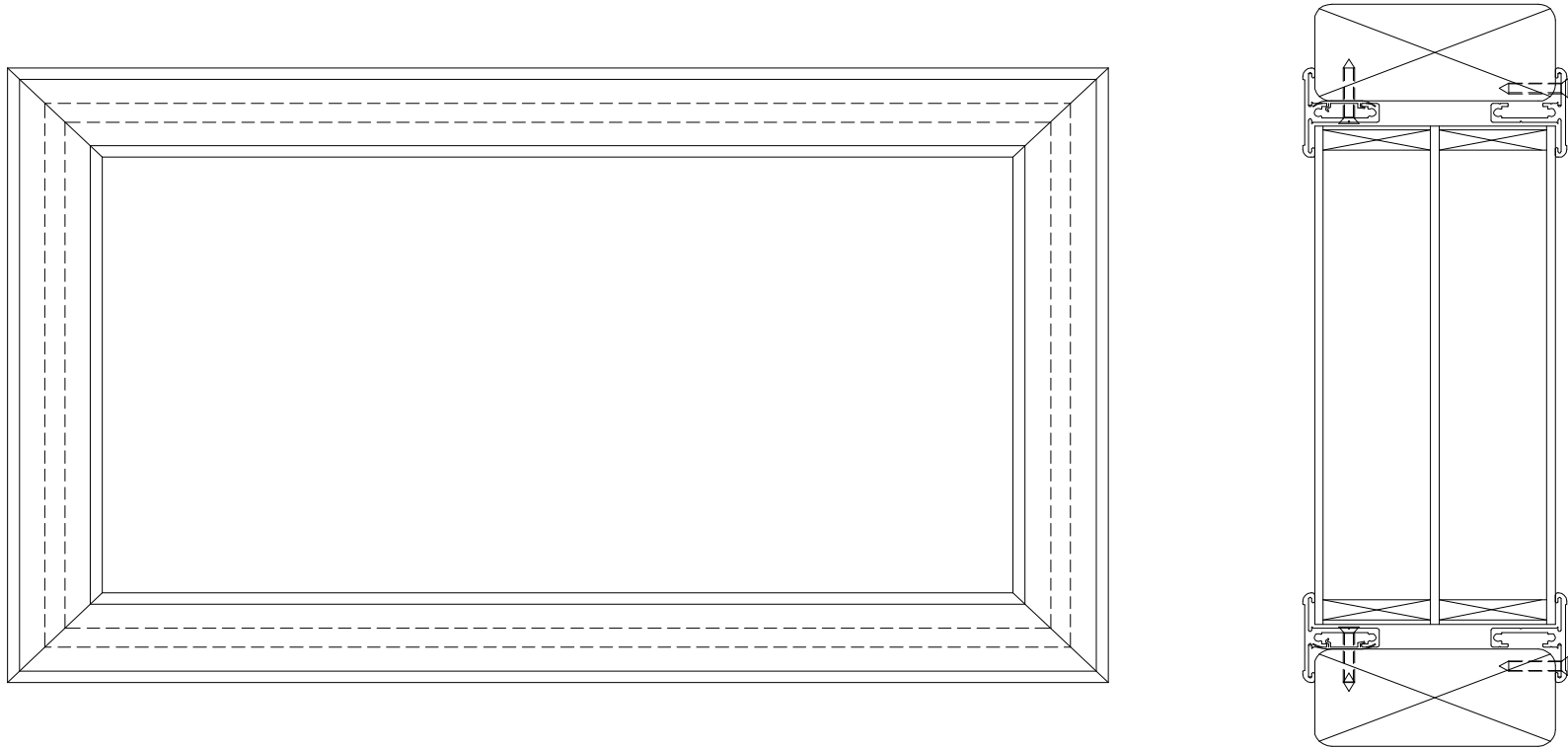

Multiple Window Assembly